

## 8mm Semi-Fixed Carbon Potentiometer

SH-085



Part Number

SH-085 – **5K**

Resistance Value

### Dimensions

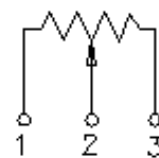
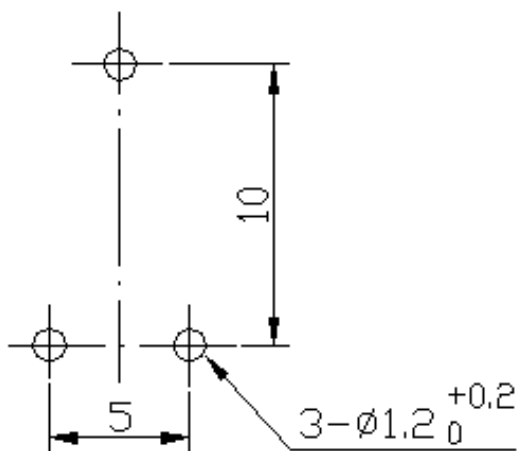
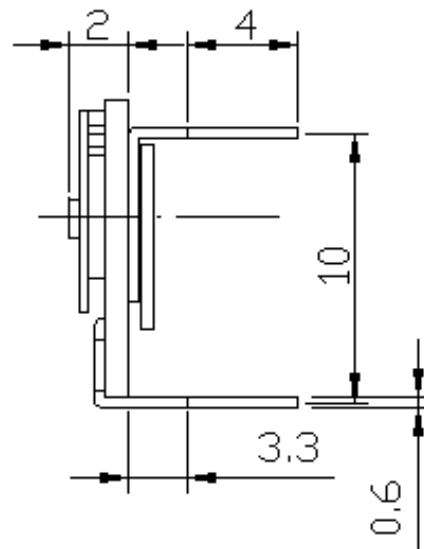
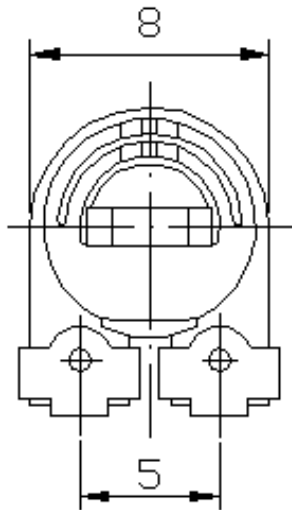

## 8mm Semi-Fixed Carbon Potentiometer

### Electrical & Mechanical Characteristics

1	Resistance Range	100 ohm    2 M ohm
2	Resistance Tolerance	+ /- 20%
3	Resistance Taper	B Curve ( Linear Change with 45°)
4	Rated Power	0.1 Wattage
5	Max. Operating Voltage	100 V
6	Rotating angle	250° ± 20 %
7	Rotating Torque	40 - 250 g - cm.
8	Rotating Strength	Min. 1 Kg - cm.
9	Rotating Life	±10% Resistance change max. after 50 rotations (return)
10	Temperature Characteristic	+5% and -20% resistance change max. after 5 hours at 70
11	Load Characteristic	±5% resistance change after using 3 hours at a normal temperature.
12	Moisture Characteristic	±15% resistance change after 5hours within 95% humidity at 40 .