

### Description:

100 Base-TX (Fast Ethernet) RJ45 1x1 Tab-DOWN with LEDs 8-pin (JO series) integrated magnetics connector (ICM), designed to support applications, such as SOHO (ADSL modems), LAN-on-Motherboard (LOM), Hub and Switches.



JO006D21BNL shown

### Features and Benefits:

- Ⓢ RoHS peak wave solder temperature rating 260°C
- Ⓢ Suitable for CAT 5 & 6 Fast Ethernet Cable or better UTP

### Electrical Performance Summary:

- Ⓢ Meets or exceeds IEEE 802.3 standard for 100Base-TX
- Ⓢ 350 µH minimum OCL with 8mA bias current
- Ⓢ Minimum 1500Vrms isolation per IEEE 802.3 requirement

### Electrical Specifications @ 25°C — Operating Temperature 0°C to +70°C

RoHS Compliant Part Number	Turns Ratios		Mech. Drawing	EMI Fingers	LEDs <sup>1</sup> (L/R)	Insertion Loss (dB TYP)	Return Loss (dB TYP) 100W ±15W					Crosstalk (dB TYP)			Common Mode Rejection (dB TYP)		Hipot (VDC)
	TX	RX					1-65 MHz	1-10 MHz	10-30 MHz	30-60 MHz	60-80 MHz	1-30 MHz	30-60 MHz	60-100 MHz	1-50 MHz	50-150 MHz	
JO006D01BNL	1CT:1	1CT:1	A	No	G/Y	-1	-20	-16	-12	-10	-40	-35	-30	-30	-20	2250	
JO006D21N1L	1CT:1	1CT:1	D	YES	N/A	-1	-20	-16	-12	-10	-40	-35	-30	-30	-20	2250	
JO006D21BNL	1CT:1	1CT:1	B	YES	G/Y	-1	-20	-16	-12	-10	-40	-35	-30	-30	-20	2250	
JO011D01N1L	1CT:1	1CT:1	C	No	N/A	-1	-20	-16	-12	-10	-40	-35	-30	-30	-20	2250	
JO011D01BNL	1CT:1	1CT:1	A	No	G/Y	-1	-20	-16	-12	-10	-40	-35	-30	-30	-20	2250	
JO011D21N1L	1CT:1	1CT:1	D	YES	N/A	-1	-20	-16	-12	-10	-40	-35	-30	-30	-20	2250	
JO011D21BNL	1CT:1	1CT:1	B	YES	G/Y	-1	-20	-16	-12	-10	-40	-35	-30	-30	-20	2250	
JO011D21ENL	1CT:1	1CT:1	B	YES	G/G	-1	-20	-16	-12	-10	-40	-35	-30	-30	-20	2250	
JO012D21N1L	1CT:1	1CT:1	D	YES	N/A	-1	-20	-16	-12	-10	-40	-35	-30	-30	-20	2250	
JO018D21N1L	1CT:1.414	1CT:1	D	YES	N/A	-1	-20	-16	-12	-10	-40	-35	-30	-30	-20	2250	
JO018D21ENL	1CT:1.414	1CT:1	B	YES	G/G	-1	-20	-16	-12	-10	-40	-35	-30	-30	-20	2250	
JO026D01N1L	1CT:1	1CT:1	C	No	N/A	-1	-20	-16	-12	-10	-40	-35	-30	-30	-20	2250	
JO026D01BNL	1CT:1	1CT:1	A	No	G/Y	-1	-20	-16	-12	-10	-40	-35	-30	-30	-20	2250	
JO026D01ENL	1CT:1	1CT:1	A	No	G/G	-1	-20	-16	-12	-10	-40	-35	-30	-30	-20	2250	
JO026D21N1L	1CT:1	1CT:1	D	YES	N/A	-1	-20	-16	-12	-10	-40	-35	-30	-30	-20	2250	
JO026D21BNL	1CT:1	1CT:1	B	YES	G/Y	-1	-20	-16	-12	-10	-40	-35	-30	-30	-20	2250	
JO026D21ENL	1CT:1	1CT:1	B	YES	G/G	-1	-20	-16	-12	-10	-40	-35	-30	-30	-20	2250	
JO026D21FNL <sup>2</sup>	1CT:1	1CT:1	B	YES	G/Y	-1	-20	-16	-12	-10	-40	-35	-30	-30	-20	2250	
JO026D21GNL <sup>3</sup>	1CT:1	1CT:1	B	YES	YG/G	-1	-20	-16	-12	-10	-40	-35	-30	-30	-20	2250	
JO0-0014N1L	1CT:1	1CT:1	C	No	N/A	-1	-20	-16	-12	-10	-40	-35	-30	-30	-20	2250	
JO0-0045N1L	1CT:1	1CT:1	A	No	G/Y	-1	-20	-16	-12	-10	-40	-35	-30	-30	-20	2250	
JO0-0061N1L	1CT:1	1CT:1	F	YES	N/A	-1	-20	-16	-12	-10	-40	-35	-30	-30	-20	2250	
JO0-0065N1L	1CT:1	1CT:1	E	YES	G/Y	-1	-20	-16	-12	-10	-40	-35	-30	-30	-20	2250	

Notes: 1. LEDs Left/right: G=green, Y=yellow, N/A=none, YG=Bi-color LED Yellow Green. 2. LEDs with internal resistor. 3. Bi-color Left LED.

### RJ45 Durability Testing Rating

Part Number	Mating Force (MAX)	Unmating Force (MAX)	Durability	Plug to Jack Retention (MIN)
JO Series	5 lbs./2.268 kgs.	5 lbs./2.268 kgs.	750 Insertions	20 lbs./9.072 kgs.

### RJ45 Material Specification

Part Number	Shield		Contact		Housing		MSL <sup>3</sup> Rating	
	Material	Finish	Material	Plating Area	Solder Area <sup>2</sup>	Material		Specification
JO Series	Brass	10-20m inches Nickel over 10-20m inches Brass	Phosphor Bronze	Nickel underplating and selective gold plating 15µ inches	120µ inches Sn100 over 50µ inches nickel	Thermoplastic	UL 94 V-0	1

Notes: 1. Connector dimensions comply with FCC dimension requirements. 2. RoHS parts are tin matte finish over nickel. 3. MSL = Moisture Sensitivity Level rating from 1 to 5 (highest = 1, lowest = 5)

J0 Series Mechanicals

A

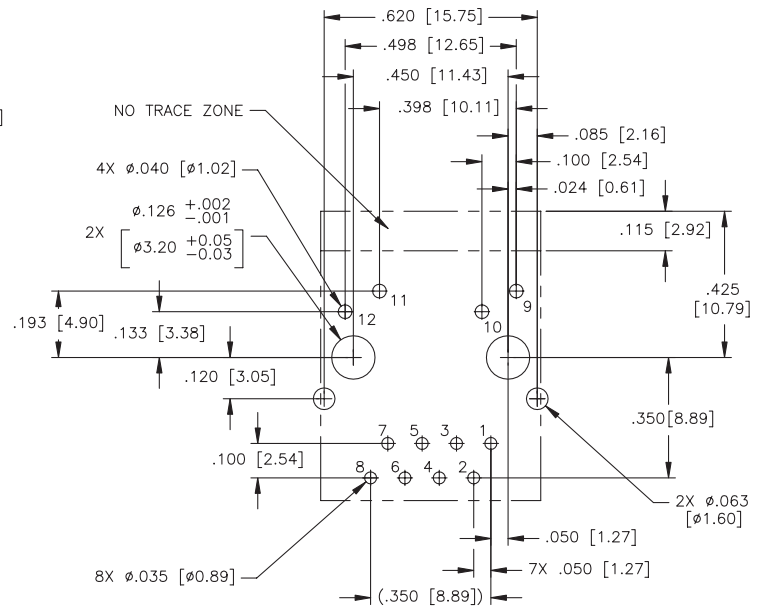
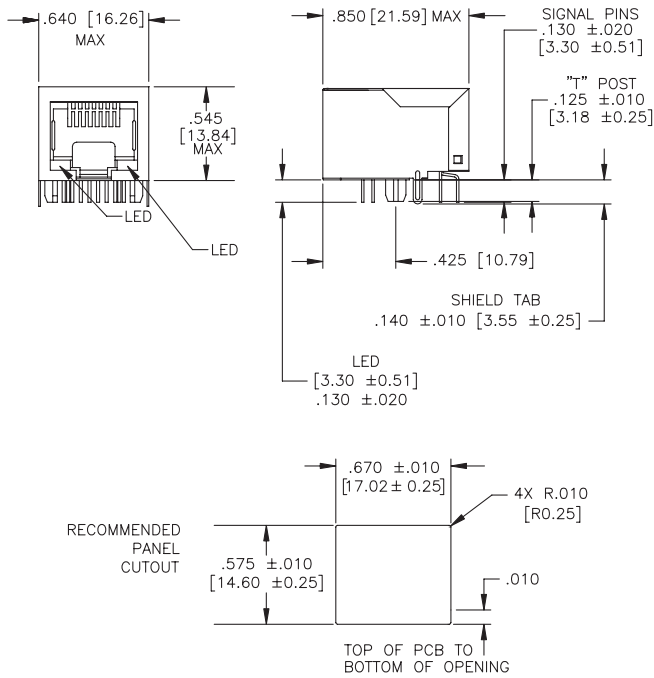

SUGGESTED PC BOARD LAYOUT VIEWED FROM COMPONENT SIDE  
PCB LAYOUT DIMENSIONS TO BE ±.002 UNLESS OTHERWISE SPECIFIED  
SCALE: 4/1

B

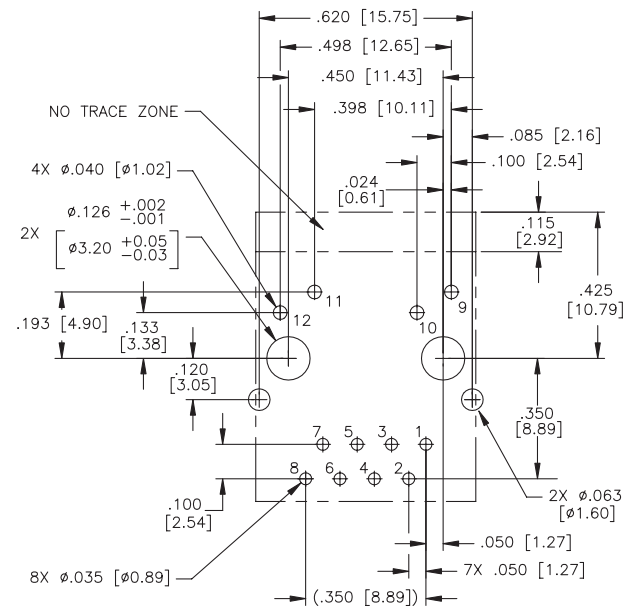
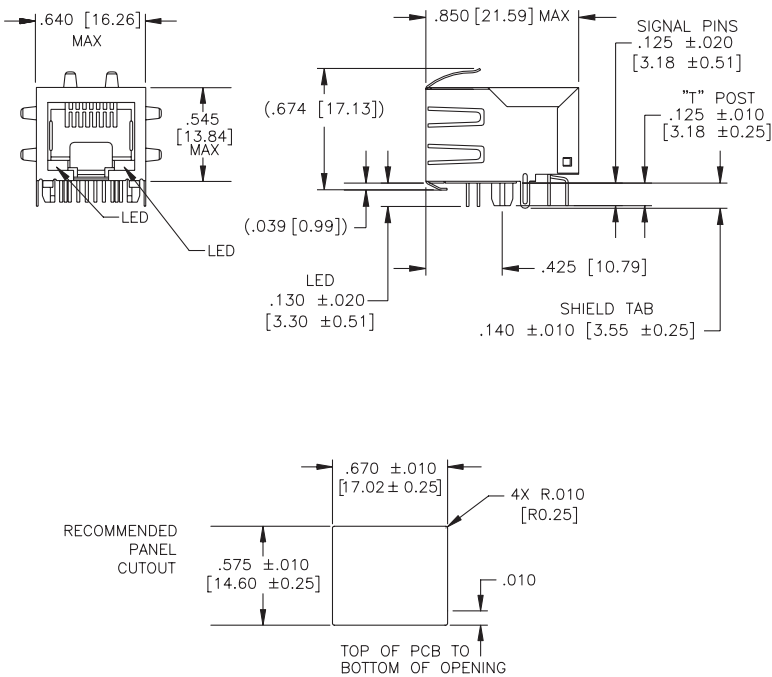

SUGGESTED PC BOARD LAYOUT VIEWED FROM COMPONENT SIDE  
PCB LAYOUT DIMENSIONS TO BE ±.002 UNLESS OTHERWISE SPECIFIED  
SCALE: 4/1

Dimensions:  $\frac{\text{Inches}}{\text{mm}}$   
Unless otherwise specified, all tolerances are ±.010 / 0.25

J0 Series Mechanicals (continued)

C

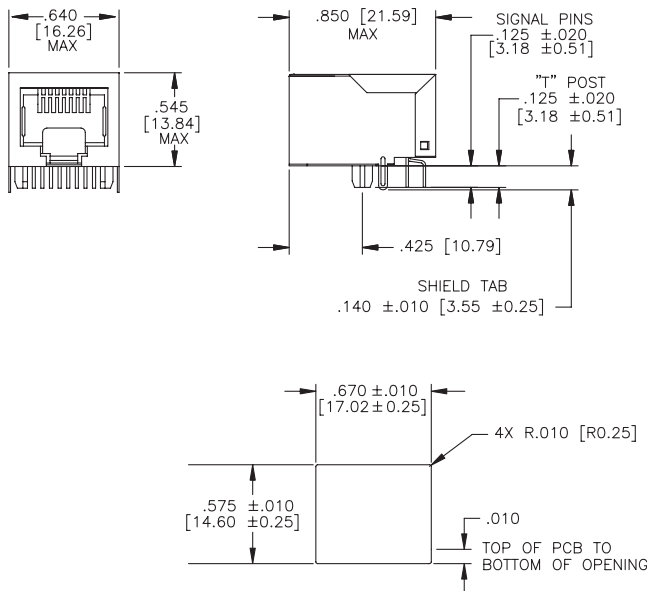

RECOMMENDED PANEL CUTOUT

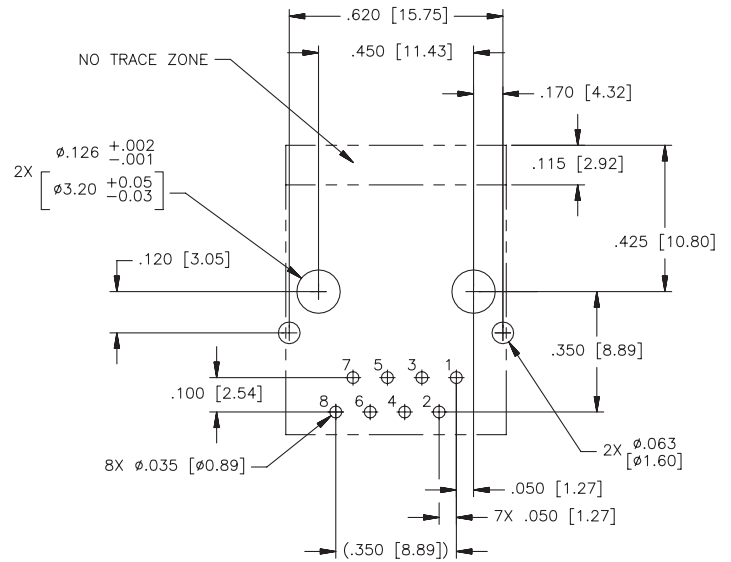

SUGGESTED PC BOARD LAYOUT VIEWED FROM COMPONENT SIDE  
PCB LAYOUT DIMENSIONS TO BE ±.002 UNLESS OTHERWISE SPECIFIED  
SCALE: 4/1

Dimensions: Inches  
mm

Unless otherwise specified, all tolerances are ±.010 / 0.25

D

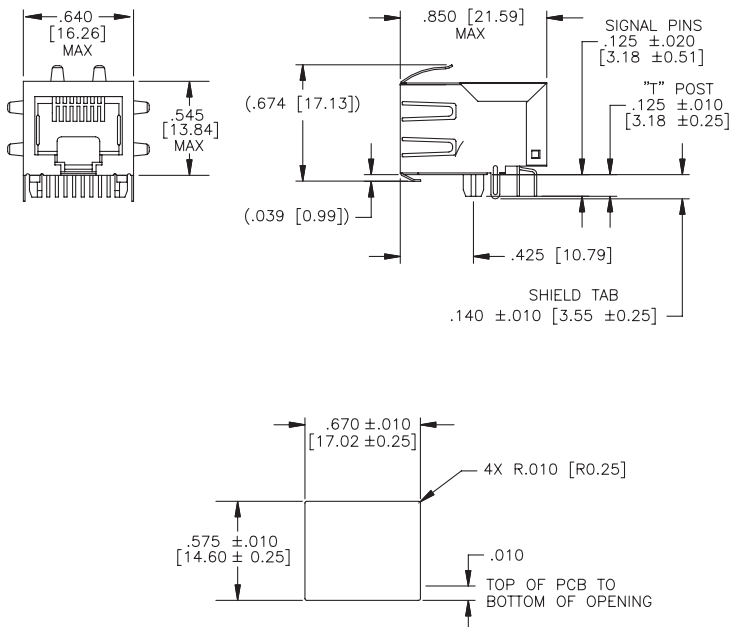

RECOMMENDED PANEL CUTOUT

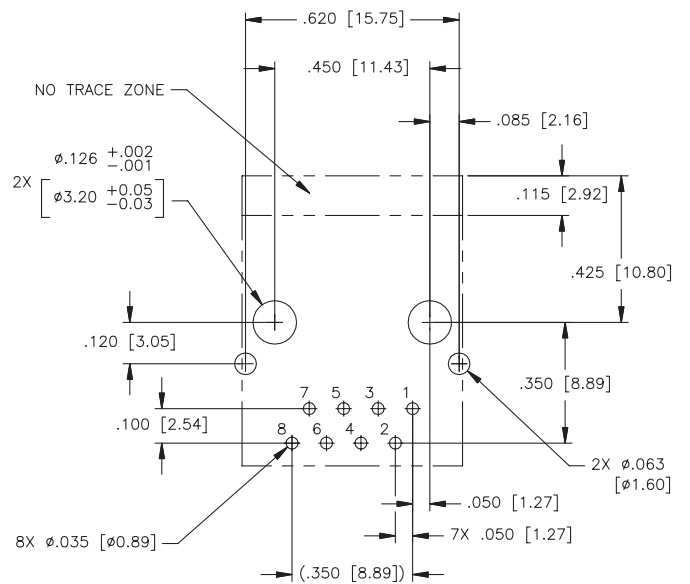

SUGGESTED PC BOARD LAYOUT VIEWED FROM COMPONENT SIDE  
PCB LAYOUT DIMENSIONS TO BE ±.002 UNLESS OTHERWISE SPECIFIED  
SCALE: 4/1

J0 Series Mechanicals (continued)

E

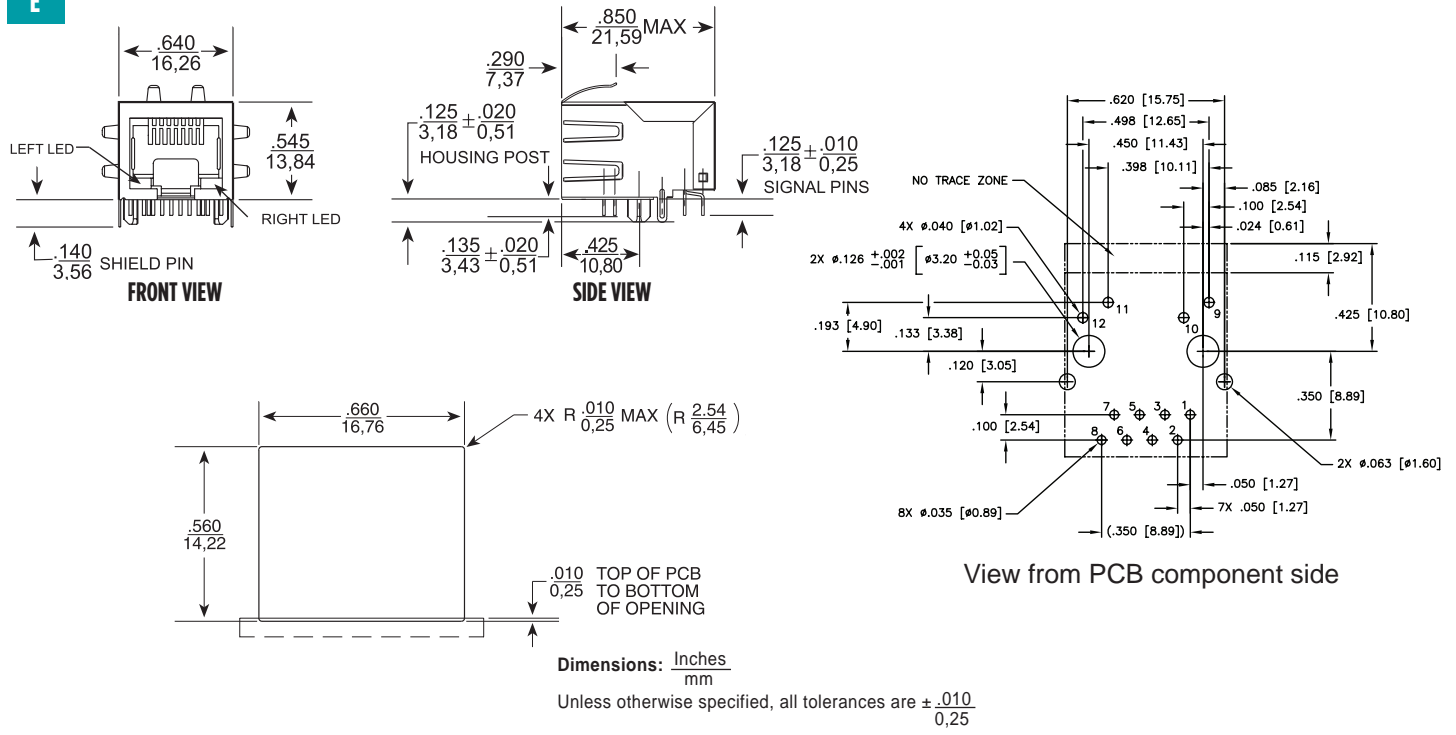

F

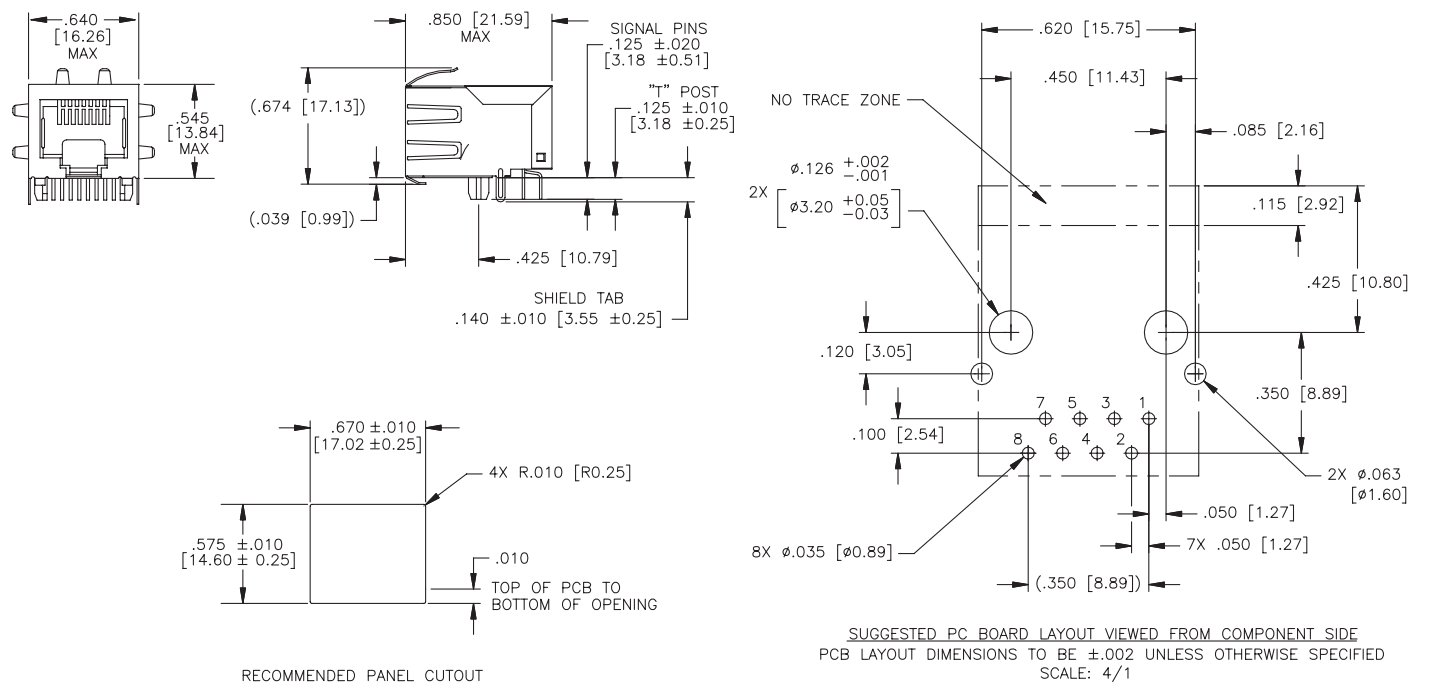

### J0 Series Electrical Schematics

#### J0006

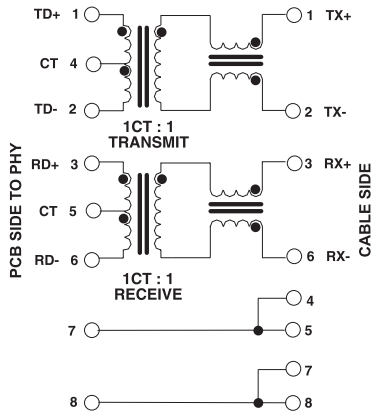

#### J0011/J00-0014NL/45NL/61NL/65NL

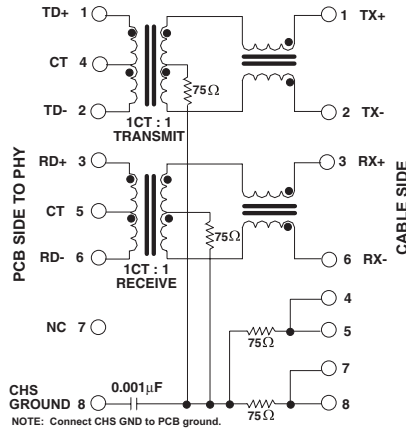

#### J0012

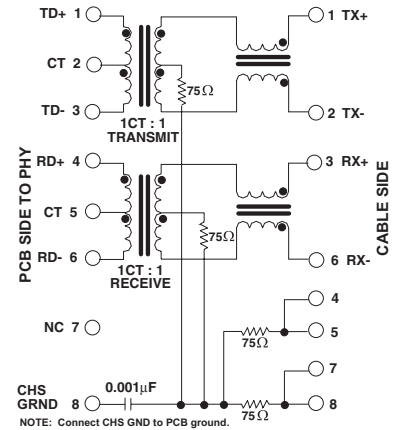

#### J0018

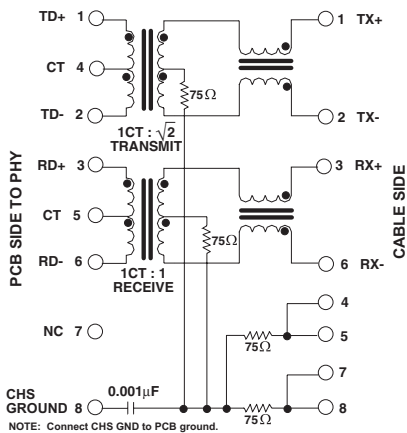

#### J0026

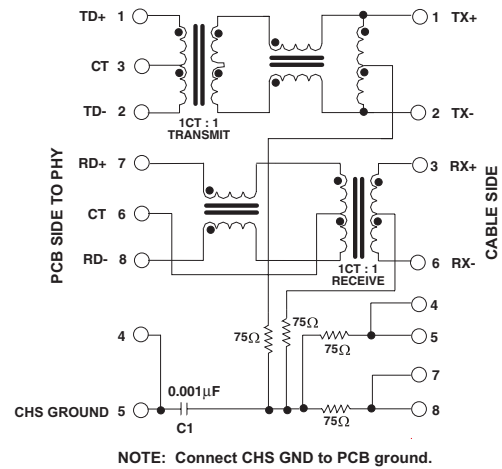

## LED Configuration

### LEDs without internal resistors

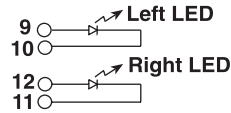

### LEDs with internal resistors

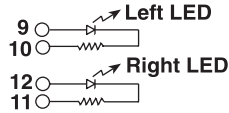

### Bi-color LED option with internal resistors

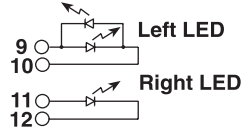

Standard LED	Wavelength	Forward* V(MAX)	(TYP)
Yellow	585 nm	2.5 V	2.1 V
Green	565 nm	2.5 V	2.2

\* Using an internal resistor within the LED increases the voltage rating of the diode from 2.5 V to 5.0 V (assumes bias current = 20 mA).

## For More Information

### Pulse Worldwide Headquarters

12220 World Trade Drive  
San Diego, CA  
92128  
U.S.A.

Tel: 858 674 8100

### Pulse Europe

Einsteinstrasse 1  
D-71083 Herrenberg  
Germany

Tel: 49 7032 7806

### Pulse China Headquarters

B402, Shenzhen Academy of  
Aerospace Technology Bldg.  
10th Kejian Road  
High-Tech Zone  
Nanshan District  
Shenzhen, PR China  
518057

### Pulse North China

Room 2704/2705  
Super Ocean Finance  
Ctr.  
2067 Yan An Road  
West  
Shanghai 200336  
China

### Pulse South Asia

135 Joo Seng Road  
#03-02  
PM Industrial Bldg.  
Singapore 368363

Tel: 65 6287 8998  
Fax: 65 6287 8998

### Pulse North Asia

3F, No. 198  
Zhongyuan Road  
Zhongli City  
Taoyuan County 320  
Taiwan R. O. C.  
Tel: 886 3 4356768  
Fax: 886 3 4356823  
(Pulse)

Performance warranty of products offered on this data sheet is limited to the parameters specified. Data is subject to change without notice. Other brand and product names mentioned herein may be trademarks or registered trademarks of their respective owners. © Copyright, 2012. Pulse Electronics, Inc. All rights reserved.