

PRODUCT SPECIFICATION

17251HSL AC220V

172×150×51mm

NO	检测项目 TEST ITEM	技术参数 SPECIFICATION/CONDITION	
1	安规认证 SAFETY AGENCY' S APPROVAL	CE	
2	尺寸 DIMENSION	172×150×51mm	
3	额定电压 RATED VOLTAGE	230 VAC	
4	工作电压范围 OPERATING VOLTAGE RANGE	220 VAC~240 VAC	
5	启动电压 START-UP VOLTAGE	154 VAC	
6	额定电流 RATED CURRENT (A)	50Hz	0.23-0.25A
		60Hz	0.20-0.22A
8	额定功率 RATED INPUT POWER (W)	50Hz	38W
		60Hz	32W
10	风量 AIR FLOW (CFM)	50Hz	155CFM
		60Hz	170CFM
12	风压 AIR PRESSURE (mmH ₂ O)	50Hz	7.5 (mmH ₂ O)
		60Hz	9.7 (mmH ₂ O)
14	转速 ROTATIONAL SPEED (R. P. M.)	50Hz	2600±10% (R. P. M.)
		60Hz	2700±10% (R. P. M.)
16	噪音 ACOUSTICAL NOISE (dB-A)	50Hz	49dB-A (42dBMAX)
		60Hz	53dB-A (42dBMAX)
18	绝缘阻抗 INSULATION RESISTANCE	500VDC ≥100MΩ	
19	绝缘耐压 INSULATION & VOLTAGE RESISTANCE	1800VAC (50Hz) ≤0.5mA 3S	
20	平均寿命 LIFE EXPECTANCE	在温度 25℃, 相对湿度 15%~65%条件下平均寿命为 20,000 小时 20,000 HRS AT TEMP. 25℃, 15%~65RH	
21	工作温度 OPERATING TEMPERATURE	-10℃~+65℃	
22	储存温度 STORAGE TEMPERATURE	-15℃~+70℃	
23	重量 WEIGHT	800 g	
24	马达保护 MOTOR PROTECTION	阻抗保护 IMPEDANCE PROTECTION	
25	绝缘等级 INSULATION CLASS	CLASS B	
26	轴承类型 BEARING SYSTEM	含油轴承	
27	外框 FRAME	AL (ADC12)	
28	定子与转子 STATOR&ROTOR	中钢 SILICON STEEL	
29	扇叶 FAN BLADE	PBT 扇叶	

2、产品图纸

PRODUCT DRAWING

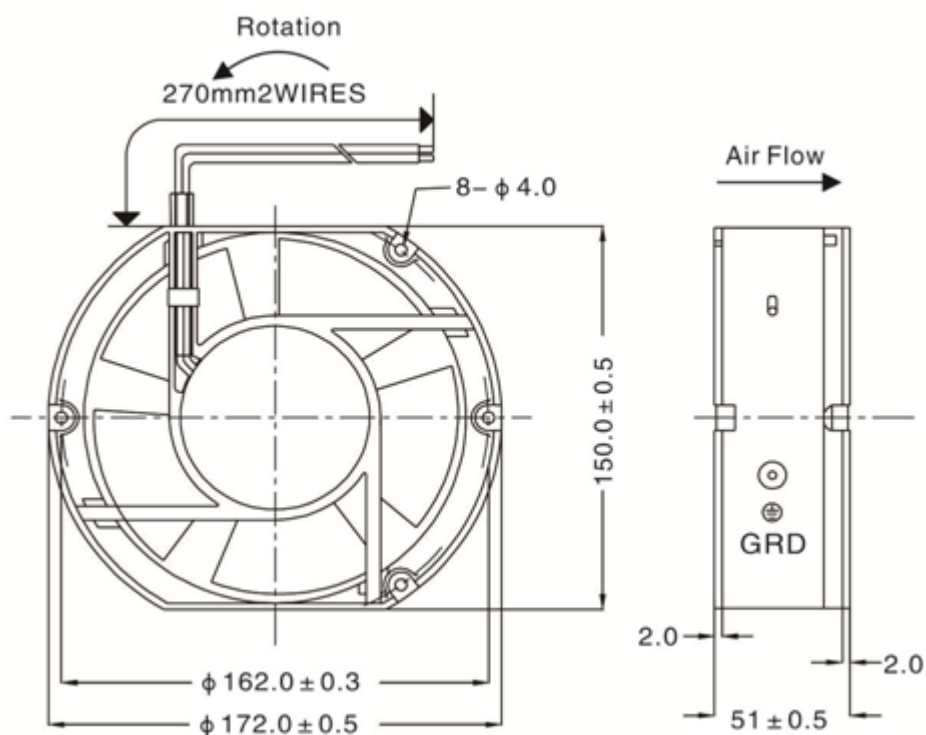

尺寸单位：毫米

DIMENSIONS UNIT:MM

APPROVED DATE	兰东阳	PART NO.	17251BL2
REVIEWED DATE	张明杰	PAGE	A
PREPARED DATE	张梅连	深圳市福盛电机有限公司	