



東莞市智旭電子有限公司
 JYH HSU (JEC) ELECTRONICS LTD.,

文件编号 Document no. :P003
 版本 Version: 5
 制订日期 Date: 2020/04/01

承認書

SPECIFICATION FOR APPROVAL

产品系列: CERAMIC DISC CAPACITORSDC

客户名称

Customer

品名

Part Name

陶瓷电容器

客户料号

Customer Part No:

承認規格

Approve Item

供应商料号

Part Number

日期

Date

2022-06-07

客户承认

Customer Acknowledgement

供应商承认

Supplier Acknowledgement



规格目录中所列的产品，材料和尺寸其他内容如有更改，恕不另行通知。

The products, materials and dimensions listed in the specification catalog are subject to change without prior notice.

零件编码原则 Part Number Configuration:

J2 102 M 3A Y5V S T 5 L E
(1) (2) (3) (4) (5) (6) (编带) (7) (8) (9)(10)

- (1) 产品类别 DC capacitors, safety
- (2) 标称容量 Rated capacitance
- (3) 误差 Tolerance on rated capacitance
- (4) 额定电压 Rated Voltage
- (5) 温度特性 Type code **Temperature Characteristic:**
(B)Y5P, (F)Y5V, (E)Y5U. NP0. SL
- (6) 脚型 Lead shape:S(直角), I(内弯), O(外弯), X(前后弯)
- (7) 脚距 Pin pitch : 5.0、7.5、9.5、10.0 、12.5
- (8) 脚长 Lead length: 3—30mm
- (9) 涂装材料 Coating material: E 代表 EPOXY,蓝色;
- (10) 电极材质 electrode material

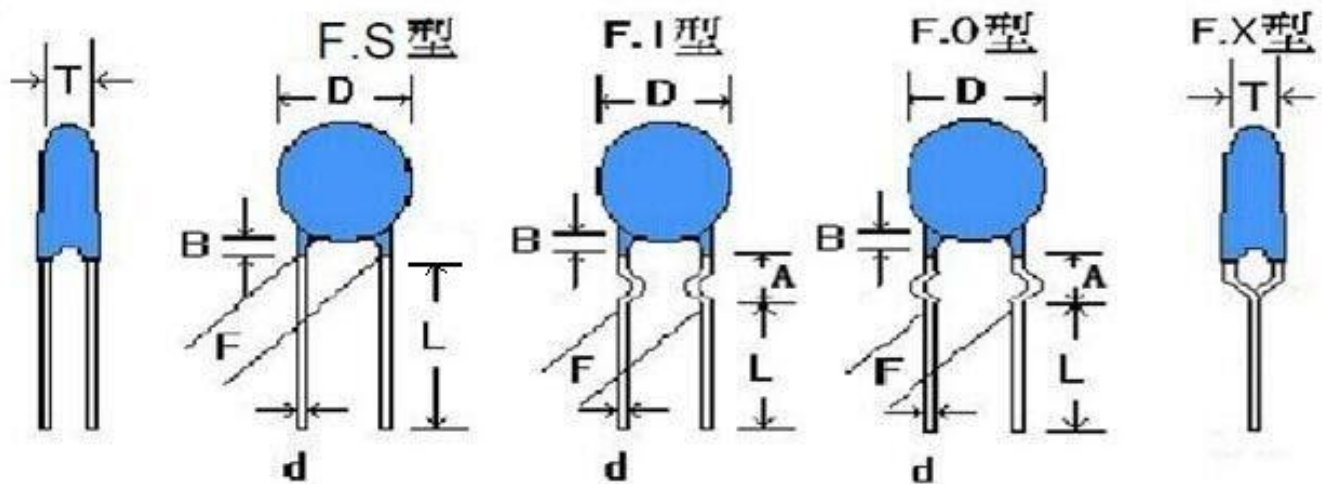

Dimensions and Tolerance

B=3.0mm max for AA

L=3-30mm

承认规格详细参数 (Approved Spec. Data)

品名规格 Approve Item	外径 D max	脚距 F±0.8	厚度 T±0.5mm	脚长 L MINmm	线径 d±0.05mm	绝缘脚 B	颜色 color	DF/Q 值	Amm	备注 Note
Y5P 101K/1KV	5.8	5.0	2.5	25.0	0.48	≅2.0	蓝色	≅2.5%	/	
Y5P 221K/1KV	5.8	5.0	2.5	25.0	0.48	≅2.0	蓝色	≅2.5%	/	
Y5V 472M/3KV	9.3	7.5	3.5	25.0	0.55	≅2.0	蓝色	≅5.0%	/	
Y5V 103M/3KV	12.7	7.5	3.5	25.0	0.55	≅2.0	蓝色	≅5.0%	/	
SL 10K/6.3KV	6.3	7.5	3.5	25.0	0.55	≅2.0	蓝色	≅1.0%	/	
SL 33K/6.3KV	6.3	7.5	3.5	25.0	0.55	≅2.0	蓝色	≅1.0%	/	
Y5P 221K/3KV	6.3	7.5	3.5	25.0	0.55	≅2.0	蓝色	≅2.5%	/	
Y5V 472M/2KV	7.4	7.5	3.0	25.0	0.55	≅2.0	蓝色	≅5.0%	/	

规格目录中所列的产品，材料和尺寸其他内容如有更改，恕不另行通知。

The products, materials and dimensions listed in the specification catalog are subject to change without prior notice.

1. 適用範圍 (Scope of Application)

適用於電子機器、儀 表、通信器材及資訊產品之絕緣圓板形固定陶瓷電容器。

Ideal for use on Electrical Appliance、Instrument、Communication equipment and Information product.

1. 種類 (Type)

- 2-1 • CLASS 1 溫度補償型(Temperature compensation type) (TC TYPE)
- 2-2 • CLASS 2 高介電常數(High inductivity) (HI - K TYPE)
- 2-3 • CLASS 3 半導體(Semi-Conductive) (SC TYPE)

3 • 溫度范围 (Temperature Range)

- 3-1 • Y 级 (Y Type) (- 25°C — + 85°C) 溫度特性范围(Operating Temperature Range)
- 3-2 • Z 级 (Z Type) (+ 10°C — + 85°C) 溫度特性范围(Operating Temperature Range)
- 3-3 • X 级 (X Type) (- 55°C — + 125°C) 溫度特性范围(Operating Temperature Range)
- 3-4. Y 级, Z 级 (-40°C — +125°C) 工作溫度范围 (Use temperature range)

4 • 額定電壓 (Rated Voltage)

- 4-1 • TC & Hi - k . . . 50V • 500V • 1KV • 2KV • 3KV • 6KV • 8KV • 10KV • 15KV (D • C)
- 4-2 • SC 16V • 25V • 50V • 100V
- 4-3 • T.C. 標示法

高压电容: HIGH DIELECTRIC CONSTANT CAPACITOR

B:Y5P/X7R D:Y5T/Y5R E:Y5U F:Y5V

5 • 溫度特性 (Temperature Characteristics)

5-1 • CLASS 1 (溫度係數 Temperature Coefficient : PPM / °C)

代 號 Code	PPM / °C	溫度係數容許差 Temperature Coefficient Change		顏 色 Color	EIA 規格 Specification	代 號 Code	W • V
		代 號 Code	PPM/ °C				
C	0	H	± 60	黑 black	NPO	C0	50V 15KV
H	-30	H	± 60	棕 brown	N33	S1	
L	-80	H	± 60	红 red	N80	U1	
P	-150	H	± 60	橙 orange	N150	P2	
R	-220	H	± 60	黄 yellow	N220	R2	
S	-330	H	± 60	绿 green	N330	S2	
T	-470	H	± 60	蓝 blue	N470	T2	
U	-750	J	± 120	紫 purple	N750	U2	
D	'-3300	L	± 500	N 330 ± 500		S 2 L	
SL	+ 140 > @ > - 1000						

T • C • CHART

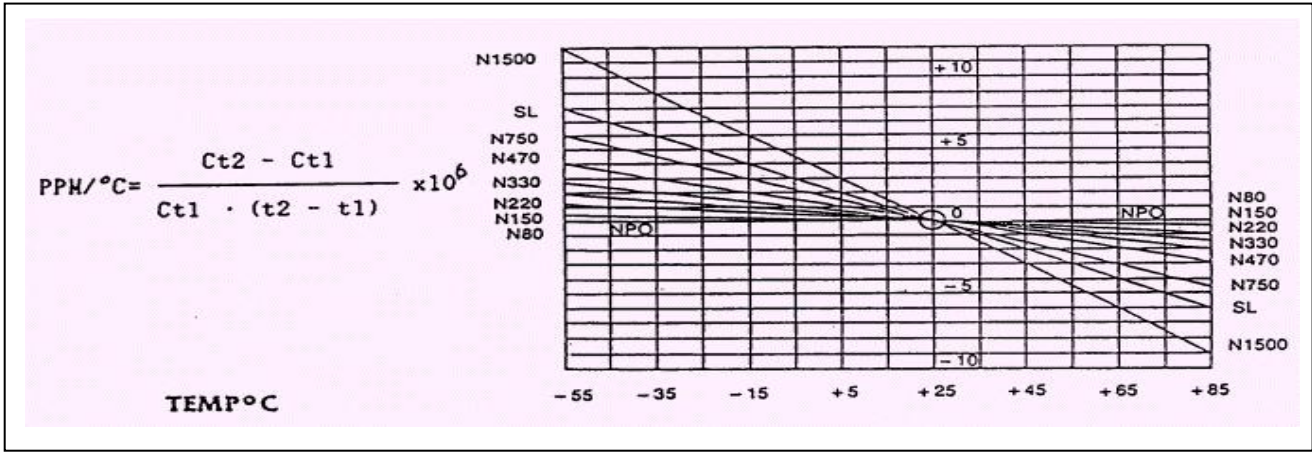

5 - 2 CLASS 2 (溫度變化率 Temperature Coefficient : %)

代 號 Code	溫度範圍 Temperature Range	容量變化率 Capacitance Tolerance	E I A 規格(Specification)		W · V
			代 號 Code	容量變化率 Capacitance Tolerance	
B	-25°C +85°C	+ 10 % / - 10 %	Y5P/YL	+ 10 % / - 10 %	50V-15KV
D		+ 20 % / - 30 %	Y5T/Y5R	+ 22 % / - 33 %	50V-15KV
E	-25°C +85°C	+ 20 % / - 55 %	Y5U/Z5U	+ 22 % / - 56 %	50V-20KV
F		+ 30 % / - 80 %	Y5V/Z5V	+ 22 % / - 82 %	50V-20KV
R	-55°C + 125°C	+ 15 % / - 15 %	X7R	+ 15 % / - 15 %	50V-2KV

5 - 3 CLASS 3 (溫度變化率 Temperature Coefficient : %)

代 號 Code	溫度範圍 Temperature Range	容量變化率 Capacitance Tolerance	E I A 規格(Specification)		W.V
			代號 Code	容量变化率 Capacitance Tolerance	
D	-25°C +85°C	±15 %	Y5R	±15 %	16V.25V 50V,100V
		+ 20 % - 30 %	Y5T	+22 % -33 %	
+30 % -80 %		Y5V/Z5V	+22 % -82%		
+20 % -55 %		Y5U/Z5U	+22 % -56 %		
± 10 %		Y5P	±10 %		

Capacitance Temperature Characteristics

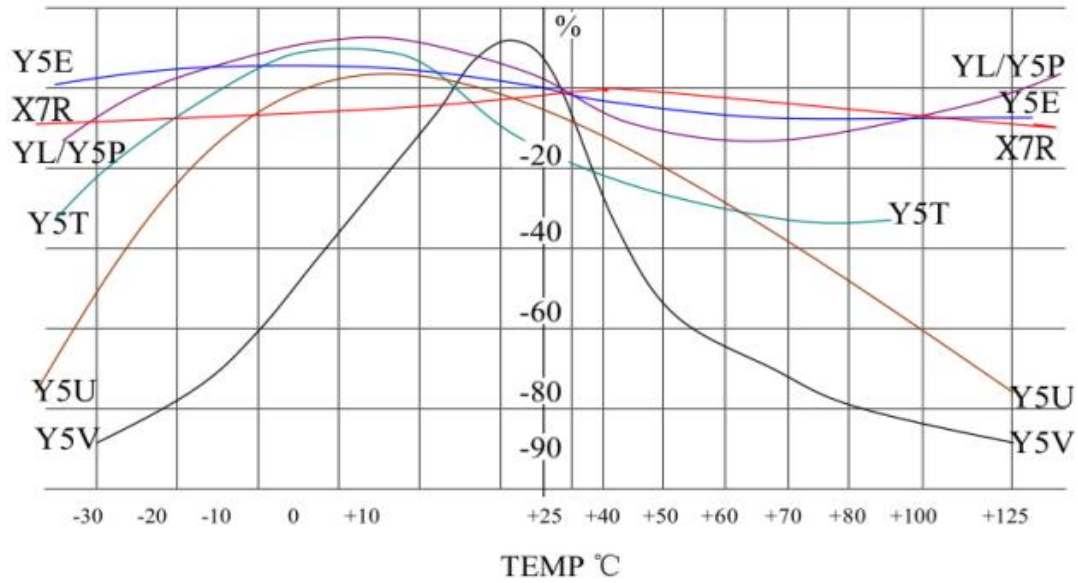

6・製品尺寸與容量範圍 (Dimensions and Capacitance Range)

本规格书尺寸,脚距,仅供参考.尺寸如有变化,不另行通知. 请向我司查询或按贵司要求生产.

Size of this specification, foot distance, for reference only. Size change without notice. Please check with us or produce according to your requirement.

6 - 1 CLASS 1

Dimension(mm)			Capacitance Range(PF)						
直徑 Diameter (D)MAX	導線間隔 Lead Space (F)		50V NPO- N750	50V N750	50V SL	500V NPO	500V-3KV	4KV-6KV	8KV-15KV
	直長腳 Straight Lead	彎短腳 Formed Lead							
5.0	2.5 ± 0.8	5.0 ± 0.8	1 - 50	1 - 50	22 - 150				
6.0	5.0 ± 0.8	5.0 ± 0.8	51 - 82	51 - 82	151 - 220	1 - 30	1 - 82	47 - 68	18 - 47
7.0	5.0 ± 0.8	5.0 ± 0.8	82 - 120	83 - 120	240 - 330			82 - 100	56 - 82
8.0	5.0 ± 0.8	5.0 ± 0.8	121 - 180	130 - 180	360 - 470	33 - 47	91 - 160	151 - 221	100
9.0	5.0 ± 0.8	5 ± 0.8	181 - 220	181 - 220	500 - 560			271	151
10.0	5.0 ± 0.8	5.0 ± 0.8	221 - 270	221 - 270	561 - 820	51 - 120	180 - 300	331	181 - 221
12.0	5.0 ± 0.8 7.5 ± 0.8	5.0 ± 0.8 9.25 ± 0.8	271 - 330	271 - 330	561 - 820	51 - 120	180 - 300	331	181 - 221
14.0	5.0 ± 0.8 7.5 ± 0.8		331 - 470	471	170 - 240	470 - 240	470 - 560	561 - 681	391

6 - 2 CLASS 2

EIA 温度特性图 TEMPERATURE CHARACTERISTIC CHART																										
X: - 55°C Y: - 25°C Z: - 10°C	4: + 65°C 5: + 85°C 6: + 105°C 7: + 125°C 8: + 150°C	<table border="1"> <tr><td>A</td><td>± 1.0 %</td></tr> <tr><td>B</td><td>± 1.5 %</td></tr> <tr><td>C</td><td>± 2.2 %</td></tr> <tr><td>D</td><td>± 3.3 %</td></tr> <tr><td>E</td><td>± 4.7 %</td></tr> <tr><td>F</td><td>± 7.5 %</td></tr> <tr><td>P</td><td>± 10 %</td></tr> <tr><td>R</td><td>± 15 %</td></tr> <tr><td>S</td><td>± 22 %</td></tr> <tr><td>T</td><td>± 22 % - 33%</td></tr> <tr><td>U</td><td>± 22 % - 56%</td></tr> <tr><td>V</td><td>± 22 % - 82%</td></tr> </table>	A	± 1.0 %	B	± 1.5 %	C	± 2.2 %	D	± 3.3 %	E	± 4.7 %	F	± 7.5 %	P	± 10 %	R	± 15 %	S	± 22 %	T	± 22 % - 33%	U	± 22 % - 56%	V	± 22 % - 82%
A	± 1.0 %																									
B	± 1.5 %																									
C	± 2.2 %																									
D	± 3.3 %																									
E	± 4.7 %																									
F	± 7.5 %																									
P	± 10 %																									
R	± 15 %																									
S	± 22 %																									
T	± 22 % - 33%																									
U	± 22 % - 56%																									
V	± 22 % - 82%																									
第一个 最低温度 First Digit is low Temperature	第二个 最高温度 Second Digit is High Temperature	最后一个字母 电容量变化, 温度范围 25°C. Last Digit is Capacitance Change Over Temperature Range From + 25 C Reading																								

尺寸 Dimension (MM)	直徑 Diameter (D) MAX		5.0	6.0	7.0	8.0	9.0	10.0	12.0	14.0	16.0	18.0	23.0
	Space	导线间隔 (F) Lead	彎短腳 Formed Lead		5.0±0.8	5.0±0.8	5.0±0.8	5.0±0.8	7.5±0.8	7.5±0.8 10.0±0.8			
		直短腳 Straight short Lead	5.0±0.8	5.0±0.8	5.0±0.8	5.0±0.8	5.0±0.8	5.0±0.8 7.5±0.8	7.5±0.8 10.0±0.8	10.0±0.8 12.5±0.8			
		直长脚 Straight long Lead	2.5±0.8	5.0±0.8	5.0±0.8	5.0±0.8	5.0±0.8 7.5±0.8	5.0±0.8 7.5±0.8	7.5±0.8 10.0±0.8	10.0±0.8 12.5±0.8			
容量 范围 Capacitance Range (PF)	50 V	B(Y5P/Y5T/ YL)	101 - 222	272 -330	392 -472	562 -822	203-223						
		E(Y5U)	102 - 103	682 - 103	123	153-223							
		F(Y5V)	102 - 103	153 - 203	223	473							
	500V- 1KV	B(Y5P/Y5T/ YL)	101 - 501	561 - 102	122 - 152	222-472	182	562 - 103	822 - 103				
		E(Y5U)	101 - 102	152 - 222	272	332 - 392	472 - 562	682 - 103					
		F(Y5V)	102 - 122	152 - 182	202 - 222	272 - 332	392 - 103	153 - 183	203 333-	473			104
	2KV	B(Y5P/Y5T/ YL)		101 - 561	681-102	122 - 152	182 - 272	332 -103					
		E(Y5U)		102 - 122	152 - 182	202 - 272	332	392 - 472					
		F(Y5V)	101 - 102	102 - 182	202 - 222	272 - 332	392 - 682	103	223- 473				
	3KV- 4KV	B(Y5P/Y5T/ YL)		101 - 471	561 - 681	821	102 - 222	332-682					
		E(Y5U)		102 - 122	152 - 182	202 - 222	102 - 222	332-682	103				
		F(Y5V)		102 - 182	202 - 222	272	332 - 472	332-682	103				
	5KV- 6KV	B(Y5P/Y5T/ YL)	101		10 - 82	101 - 471	561 - 102	122-682					
		E(Y5U)			471 - 102	152 - 182	222	272	332 - 472	682	103		
		F(Y5V)			102 - 222	152 - 222	332 - 392	472	682	103			
	8KV- 12KV	B(Y5P/Y5T/ YL)			101 - 331	471	561 - 681	821 - 102	122	182			
		E(Y5U)			471 - 561	681 - 102	122	152 - 182	222	222	472		
		F(Y5V)			102	152 - 182	222 - 332	272 - 332	472				
	15KV- 20KV	B(Y5P/Y5T/ YL)			101 - 331	471	561 - 681	821 - 102	102-22 2	222			
		E(Y5U)			471 - 561	681 - 102	122	152 - 182	222	222	472		
		F(Y5V)			102	152	182	102-222	272	332	472	103	

6-2 CLASS 3

尺寸 Dimension (MM)	直徑 Diameter (D) MAX		5.0	6.0	7.0	8.0	10.0	11.0	12.0	14.0	
	导线 间隔 (F) Lead Space	彎短腳 Formed Lead	5.0 ± 0.8	5.0 ± 0.8	5.0 ± 0.8	5.0 ± 0.8	5.0 ± 0.8	7.5 ± 0.8	7.5 ± 0.8	10.0 ± 0.8	10.0 ± 0.8
		直短腳 Straight short Lead	2.5 ± 0.8	5.0 ± 0.8	5.0 ± 0.8	5.0 ± 0.8	5.0 ± 0.8	7.5 ± 0.8	7.5 ± 0.8	10.0 ± 0.8	10.0 ± 0.8
		直长腳 Straight long Lead	2.5 ± 0.8	5.0 ± 0.8	5.0 ± 0.8	5.0 ± 0.8	5.0 ± 0.8	7.5 ± 0.8	7.5 ± 0.8	10.0 ± 0.8	10.0 ± 0.8
容量 范 围 Capacitance Range (PF)	16 V	D Y5R	103		223	473			104		
		D Y5T	223	473 - 104							
		F Y5V	473	104							
		E Y5U	223 - 473	104							
	25 V	D Y5R	103			223	473			103	
		D Y5T	103	223		473		104	103	223	
		F Y5V	223	473 - 104	154	224			223	473 - 104	
		E Y5U	153 223	- 473	104				153 - 223	473	
	50V 100V	F Y5V	223	473	104		224				
		E Y5U								104	
		B Y5P	103								

7. 靜電容量與容許差 (Capacitance & Tolerance) :

7-1 CLASS 1

靜電電容 Capacitance	容許差 Tolerance			
	代號 Code	容量 Capacitance	代號 Code	容量 Capacitance
1 - 5 PF	C	± 0.25 PF	D	± 0.5 PF
6- - 821 PF	J	± 5 %	K	± 10 %

7-2 CLASS 2

50V	容許差 Tolerance		500V 20KV	容許差 Tolerance	
	代號 Code	%		代號 Code	%
B	K	± 10 %	B	K	± 10 %
D	M	± 20 %	R	L	± 15 %
F	Z	+ 80 % - 20 %	F	Z	+ 80 % - 20 %
E	M	± 20 %	E	M	± 20 %
	Z	+ 80 % - 20 %		Z	+ 80 % - 20 %
	P	+ 100 % - 0 %		P	+ 100 % - 0 %

7-3 CLASS 3

16V 50V	容許差 Tolerance		16V 50V	容許差 Tolerance	
	代號 Code	%		代號 Code	%
D (Y5R)	K	± 10 %	B (Y5P)	K	± 10 %
D (Y5T)	M	± 20 %	E (Y5U)	M	± 20 %
F (Y5V)	Z	+ 80 % - 20 %	R (X7R)	K	± 10 %

8.性能與試驗 (Performance and Testing)

本規格承認書所列之名稱製品規格之性能及一般試驗，特殊試驗均符合及依據 EIA RS 198, JIS C 6422, 423, GB/T 2693 等規格。

The specification recognizes the performance and general test of the product specification listed in this specification, Special tests are in accordance with and basis EIA RS 198, JIS C 6422, 6423, GB/T 2693 Specifications such as

注意：1. 依國際規範定義，耐壓測試時，零件承認或周期性試驗測試為一分鐘，經一分鐘測試之部品需報廢處理。（此測試條件帶有破壞性測試）

"Note: (1) Is was defined according with IEC, when for qualification approval and periodic tests, the withstanding test must last to 1 minute, and it belong to destroyed test domain, therefore, after the test, capacitors should be scrap. Withstand voltage test should rise slowly at 150V/s, and test time is counted from when the voltage reaches to experiment requirement." (Capacitors may cause to damage when withstand voltage test repeated.)

2. 批量生產時測試時間為三秒鐘，耐壓測試應為緩升或零啟動。

(2) The test time is more than 1 second at production period, and the rated test voltage is applied.

表(sheet) 1													
No	項目 Item	性能 Performance	試驗方法 Test method										
1	外觀及尺寸 Appearance and Dimensions	參考 6 , 9 , 10 頁之圖表 refer to charts on page (6, 9, 10)	1-1 生產線必須做全數外觀檢驗並分別剔除不良品。 1-2 尺寸利用微測儀或卡尺測量。 "Production line visual inspection must be done in full and remove the defective products." Dimensions should be measured with slide calipers and micrometers.										
2	記號標示 Marking	必須乾淨及清晰。 had to cleanness and clearly	2-1 標示需能承受溶劑擦拭。 Marks need can bear solvent wipe.										
3	耐電壓 Withstanding Voltage	無任何異常發生。 No failure	3-1 試驗電壓為額定電壓之倍數。 The test voltage is a multiple of the rated voltage. CLASS I 和 II (50V-500V 為三倍), CLASS III 與 (1KV~2KV) 為兩倍 , 3KV -4KV 為 1.5 倍, 5~6KV 為 1.2 倍, 8KV 以上為 1.0 倍。印加時間為 1~5 秒。充放電流限於 50 MA 以下。 CLASS 1~2 Test voltages were three times rated , CLASS 3 and over (1~2KV) type is 2 times 3~4KV type is 1.5 times, 5~6KV type is 1.2 times, >8KV type is 1 time test. times 1 ~ 5 sec. Charge / discharge current ≅ 50mA										
	端子間 Between Lead Wires		<table border="1"> <thead> <tr> <th colspan="2">特制产品 Special products</th> </tr> <tr> <th>額定电压</th> <th>倍数</th> </tr> </thead> <tbody> <tr> <td>10KV</td> <td>1.5 倍</td> </tr> <tr> <td>15KV</td> <td>1.5 倍</td> </tr> <tr> <td>20KV</td> <td>1.3 倍</td> </tr> </tbody> </table>	特制产品 Special products		額定电压	倍数	10KV	1.5 倍	15KV	1.5 倍	20KV	1.3 倍
特制产品 Special products													
額定电压	倍数												
10KV	1.5 倍												
15KV	1.5 倍												
20KV	1.3 倍												
	端子與外裝間 Body Insulation	無任何異常發生。 No failure	3-3 使用金屬小球法或金屬箔法, 以額定電壓之 2.5 倍加於端子與塗裝外層間。 參閱 GB/T2693 或 CNS 3432 。 Test with metal pellet method, 2.5 times of rated voltage is applied between the lead wires and coated. See GB/T2693 or CNS 3432										
4	絕緣電阻 (端子間) Insulation Resistance (Between Lead Wires)	CLASS 1	$\geq 10000 \text{ M}\Omega$										
		CLASS 2	10000 $\text{M}\Omega$ 或 200 Ω F 以上以較小值為準。 $\geq 10000 \text{ M}\Omega$ or 200 Ω F, take the small one.										
		CLASS 3 16V	100 $\text{M}\Omega$ 或 10 Ω F 之較小值以上 $\geq 100 \text{ M}\Omega$ or 10 Ω F, Take the small one.										
		50V . 25V	1000 $\text{M}\Omega$ 或 20 Ω F 之較小值以上 $\geq 1000 \text{ M}\Omega$ or 20 Ω F, take the small one.										
			<p>絕緣電阻之測定電壓 Measure voltage of insulation resistance</p> <table border="1"> <thead> <tr> <th>額定電壓 rated voltage</th> <th>測定電壓 Testing Voltage</th> </tr> </thead> <tbody> <tr> <td>(VR/VC) < 10V</td> <td>(VR/VC) $\pm 10\%$</td> </tr> <tr> <td>10V \leq (VR/VC) < 100V</td> <td>10 $\pm 1V$</td> </tr> <tr> <td>100V \leq (VR/VC) < 500V</td> <td>100 $\pm 15V$</td> </tr> <tr> <td>500V \leq (VR/VC)</td> <td>500 $\pm 50V$</td> </tr> </tbody> </table> <p>VR 表示額定電壓, VC 表示類別電壓。 用絕緣電阻計按上表施加電壓兩端子間, 60S 後讀其絕緣電阻值。 VR represents the rated voltage., VC represents the class voltage., The insulation resistance meter is used to apply voltage two terminals to the upper table, and the insulation resistance value is read after 60 seconds.</p>	額定電壓 rated voltage	測定電壓 Testing Voltage	(VR/VC) < 10V	(VR/VC) $\pm 10\%$	10V \leq (VR/VC) < 100V	10 $\pm 1V$	100V \leq (VR/VC) < 500V	100 $\pm 15V$	500V \leq (VR/VC)	500 $\pm 50V$
額定電壓 rated voltage	測定電壓 Testing Voltage												
(VR/VC) < 10V	(VR/VC) $\pm 10\%$												
10V \leq (VR/VC) < 100V	10 $\pm 1V$												
100V \leq (VR/VC) < 500V	100 $\pm 15V$												
500V \leq (VR/VC)	500 $\pm 50V$												
5	靜電容量 Capacitance	必須符合要求之容許差規格內。 Within specified tolerance	5-1 測定溫度 should be measured at 25 \pm 2 $^{\circ}\text{C}$										
			5-2 測定電壓 measured with this voltage: CLASS 1 < 5 V rms CLASS 2 < 3 V rms CLASS 3 < 0.1 V rms										
			5-3 測定頻率 measured with frequency range: C l a s s 1 1 M H z \pm 10 % C l a s s 2, Class 3 1 K H z \pm 10 %										

编号 No	项目 Item	性能 Performance		试验方法 Test Method				
6	Q/tan σ (%)	CLASS 1 : Q/tan σ (%)		6-1	與第 5 項同。 same as item 5			
		< 30PF Q ≧ 400+20 × C						
		> 30PF Q ≧ 1,000						
		CLASS 2 : tan σ (%)						
		D、B、E 特性 features: 2.5 % Max F 特性 features: 5.0 % Max						
		CLASS 3 : tan (%)						
16V		7.0 % Max						
50V 25V		5.0 % Max						
7	靜電容量 溫度特性 Temperature Characteristics	CLASS 1	容量漂移 Capacitance Change	必須符合 5-1 之規格 should be meet the specified range at 5-1	7-1	溫度係數 Temperature Coefficient: (CLASS 1) $PPM / ^\circ C = \frac{C_{t2} - C_{t1}}{C_{t1} \cdot (t2 - t1)}$ C t2 : 在 t2 時之容量值 (C t2 : at t2 value) C t1 : 在 t1 時之容量值 (C t1 : at t1 value) t2 : 85 °C ± 3 °C t1 : 20 °C ± 2 °C 溫度階段 Temperature step <1> 20 ± 2 °C → <2> -25 ± 2 °C → <3> 20 ± 2 °C → <4> 85 ± 2 °C → <5> 20 ± 2 °C		
			容量漂移 Capacitance Change	在 ±0.2 % 或 ±0.05 PF 以內, 取较 大者為準。 within ± 0.2 % or ± 0.05 PF, take the larger.			7-2	
		CLASS 2、3	無電壓時 Non bias	必須符合 5-2、5-3 之規格。 should be meet the specified range at 5-2 5-3。	7-3		容量變化率 Capacitance change rate: (CLASS 2、3) $C \cdot C (\%) = \frac{(C_{tx} - C_{t20})}{C_{t20}} * 10$ C tx : 溫度階段 <1> <3> <5> 除外, <2> 到 <4> 之間任何溫度時之容量值。 C tx : Capacitance at temperature step(2) & (4), but (1), (3), (5)exclusion. C t20 : 溫度階段 <3> 時之容量值。 C t20 : Capacitance at temperature step (3).	
			加壓於兩 端子間時 Bias between two terminals	B : +10 % -20 % D : +20 % -40 % E : +20 % -80 % F : +30 % -95 %				
8	端子強度 Robustness of Terminations	抗拉強度 Tensile	導線不斷裂, 電容器不破損 Lead wire should not be cut off. Capacitor should not be broken.	8-1	線 徑 Lead Dia. <mm>	負荷重 Loading kgs		時間 <秒> Time <sec>
					∅ 0.5	0.5		10
				8-2	∅ ∅ 0.6~0.8	1.0	10	
					制品固定, 負荷施力方向為端子引出之方 向。 Fix the body of the capacitor and apply a tensile weight gradually to each lead wire in the radial direction.			
		彎曲強度 Bending	導線不致被折斷, 電容器不損。 Lead wire should not be cut off. Capacitor should not be broken.	8-3	線徑 Lead Dia. <mm>	負荷重 Loading kgs	彎曲角度為 90。兩回以上 Each lead wire should be a 90 ° bend in the opposite Direction of more two bends.	
					∅ 0.5	0.25		
	∅ ∅ 0.6~0.8			0.5				

编号 No	项目 Item	性能 Performance		试验方法 Test Method		
9	耐振性 Vibration Resistance	外觀 Appearance	無顯著之異常 No marked defect	9-1	振動頻率 10 → 55 → 10 HZ 一分鐘內完全成覆振動全振幅 1.5 mm Vibrated at a frequency range of 10 → 55 → 10 HZ with about a 1 minute 1.5mm in total amplitude	
		容量變化 Capacitance	在規格範圍內 Within the specified tolerance			
		Q 或 tan σ Q or tan σ	在初期規格內 Within the specified tolerance			
10	焊錫耐熱性 Soldering heat-resistance	外觀 Appearance	無顯著之異常 No marked defect	10-1 10-2 10-3 10-4	焊錫溫度 350 ± 10 °C Soldering Temperature 350±10 °C 浸漬時間 3.5 ± 0.5 秒 Dipped time 3.5 ± 0.5 sec 在常溫常濕中放置 4 ~ 24 小時后測之。 Placed at room condition for 4~24 hrs, and test. 本體尺寸 5 m/m 以下者 270±5 °C Body dimension under 5 m/m at 270 ± 5 °C, 浸漬時間 3 ± 0.5 秒 Dipped time 3 ± 0.5 sec	
		容量變化 Capacitance Change	CLASS 1			在 ± 2.5 % 或 ± 0.25PF 以內取較大值。 within ±2.5% or ± 0.25PF, takes bigger value.
			CLASS 2 3			B : ≤ ± 5 % D : ≤ ± 10% E : ≤ ± 15% F : ≤ ± 20%
		耐电压 Dielectric Strength	无任何异常发生 No failure			
11	焊錫附著性 Solderability of Leads	導線之橫截面積上須有圓周之 3/4 以上之面積為焊錫所付著。 Lead wire should be soldered with uniform coating on the axial direction over 3/4 of the circumferential direction.		11-1 11-2	焊錫溫度為 275 ± 10 °C Soldering Temperature 275 ± 5°C 浸漬時間為 2 ± 0.5 秒。 Dipped time 2 ± 0.5 seconds.	
12	耐溶劑性 (本體) Solvent Resistance (Body)	試驗後其電性能須符合標準。 After the test must meet the standards of its electrical properties			將樣本完全浸漬於丙醇溶劑中 5±0.5 分後取出，觀察本體有無溶解，而後放置於常溫中 48 小時，量測其電氣特性。 The capacitor should be immersed into a isopropyl alcohol for 5±0.5 minutes, then removed and placed for 48 hrs. at room condition before post measurements.	

编号 No	项目 Item	性能 Performance			试验方法 Test Method	
13	耐濕性 Humidity (Under Steady State)	外觀 Appearance		無顯著之異常 No marked defect	13-1	
		容量變化 Capacitance Change	CLASS S 1	在±2.5%或±0.5PF 以內取較大值。 within ±2.5% or ±0.5PF, takes bigger value.		13-2 13-3 13-4
			CLASS S 2-3	B : ≤ ± 5 % D : ≤ ± 10 % E : ≤ ± 15 % F : ≤ ± 20 %		
		Q	CLASS 1	參考附圖 1 Refer to attached figure 1.		溫度 : 40 ± 2 °C Temperature : 40 ± 2 °C
		Tan σ (%)	CLASS 2-3	B、D、E 特性在 5%以下,F 特性 7.5%以下 B、D、E, < 5%. F, < 7.5 %		濕度 : 90 ~ 95 % RH Humidity: 90 ~ 95 %RH 時間 : 500 ± 12 小時 Time : 500 ± 12 Hrs.
			CLASS 1	≥ 1000 MΩ		取出置常溫下 1 ~ 2 小時后測定之
			CLASS 2	≥ 1000 MΩ or 20 ΩF, 取小者.take the small one.		After humidity test, placed at room condition 1~ 2 hrs, then measure it.
			CLASS 3	16V	≥ 50 MΩ or 5 ΩF,取小者.take the small one.	
				25V 50V	≥ 500 MΩ or 20 ΩF, 取小者.take the small one.	
		耐電壓 Dielectric Strength	無任何異常 No failure			

编号 No	项目 Item	性能 Performance				试验方法 Test Method				
14	耐濕負荷 Humidity Loading	外觀 Appearance		無顯著之異常 No marked defect		14-1	溫度: 40 ± 2 °C Temperature : 40 ± 2 °C 濕度: 90 ~ 95 % RH Humidity: 90 ~ 95 % RH 時間: 500 ± 12 小時 Time : 500 ± 12 Hrs 電壓: 依額定電壓印加之。 Voltage: Apply the rated voltage 電流: 50 MA 以下。 Current: < 50 MA 取出置常溫下 1~2 小時后測定之 After humidity test, placed at room condition 1~ 2 hrs, then measure it.			
		容量 變化 Capacitan ce Change	CLASS 1	在±7.5%或±0.75 PF 以內取較大值。 within ± 7.5% or ± 0.75 PF, take the lage one.		14-2		14-3	14-4	
			CLASS 2-3	B : ≤ ± 5 % D : ≤ ± 10% E : ≤ ± 15% F : ≤ ± 20%		14-5		14-6		
		Q	CLASS 2	參考附圖 1 Refer to attached figure 1.		絕緣電阻 Insulation Resistance		CLASS 1,2	≥ 500 M Ω	
		Tan σ (%)	CLASS 2	B、D、E、< 5 % F < 7.5 %				CLASS 3	16V	≥ 50 M Ω or 5 Ω F, 之較小值上 take the small one.
			CLASS 3	16V	<10%	25V 50V		≥ 500M Ω or 20 Ω F 之 較小值以上 take the small one.		
25V 50V	<7.5%	耐電壓 Dielectric Strength		無任何異常 No failure						

编号 No	项目 Item	性能 Performance		试验方法 Test Method	
15	高温 负荷 High temper ature loadin g	外觀 Appearance	無顯著之異常 No marked defect	15-1 15-2 15-3 15-4 15-5	
		容量 變化 Capacitance Change	CLASS 1	在 ±3%或±0.3 PF 以內取較大值。 Within ±3% or ±0.3 PF, take the large one.	
			CLASS 2-3	B : ≤ ± 5 % D : ≤ ± 10 % E : ≤ ± 15 % F : ≤ ± 20 %	
		Q	CLASS 1	參考附圖 1 Refer to attached figure 1.	
		Tan σ (%)	CLASS 2	B、D、E 特性在 4%以下 Char. B、D、E, <4 % F 特性 7.5%以下 Char. F <7.5 %	
			CLASS 3	16V	< 10 %
		25V 50V		< 7.5 %	
		絕緣 電阻 Insulati on Resista nce	CLASS 1	1000MΩ 以上 ≥ 1000MΩ	
			CLASS 2	≥ 1000 MΩ or 20 Ω F, 取小者。take the small one.	
			CLASS 3	16V	≥ 50 MΩ or 5 Ω F, 取小者。take the small one.
25V 50V	≥ 500 MΩ or 20 Ω F, 取小者。take the small one.				
耐電壓 Dielectric Strength	無任何異常 No marked defec				

溫度: 85 ± 3 °C
Temperature : 85 ± 3 °C
時間: 1000 ± 12 小時
Time : 1000 ± 12 hrs
電壓: 依額定電壓印加之。
Voltage: Apply the rated voltage
電流: 50 MA 以下。
Current: < 50 MA
取出置常溫下 1~2 小時后測定之
After humidity test, placed at room condition 1~2 hrs, then measure it.

附圖一 Attached figure 1	適用項目 Applied Item	規格值 Specification
	初期值 <5> 耐振性 <9> Initial Value <5> Vibration Resistance <9>	≥ 30PF Q ≥ 1000 < 30PF Q ≥ 400+20 C
	溫度以及浸漬循環 <12> 耐濕性 <13> , 高溫負荷 <15> Temperature and immersion cycle <12> , Humidity <13> , High temperature loading <15>	≥ 30PF Q ≥ 350 10PF~30PF Q ≥ 275+5 / 20 C < 10PF Q ≥ 200 +10 C
	耐濕負荷 <14> Humidity Loading <14>	≥ 30PF Q ≥ 200 < 30PF Q ≥ 100+ 10 / 3 C

成品之編碼原則上以十五碼完成，亦以阿拉伯數字與英文字母混合編成，第二碼至第十一碼與瓷片相同。第一碼以 J 代表自製（取 JEC 商標第一字）

The coding of the finished product is in principle 15 codes, which are mixed with Arabic numerals and English letters Sizes 2 to 11 are the same as the tiles The first code is represented by J (take the first word of JEC trademark).

例：J2472M3AY5VS5LE (Y5V 472M/1KV 5*25)

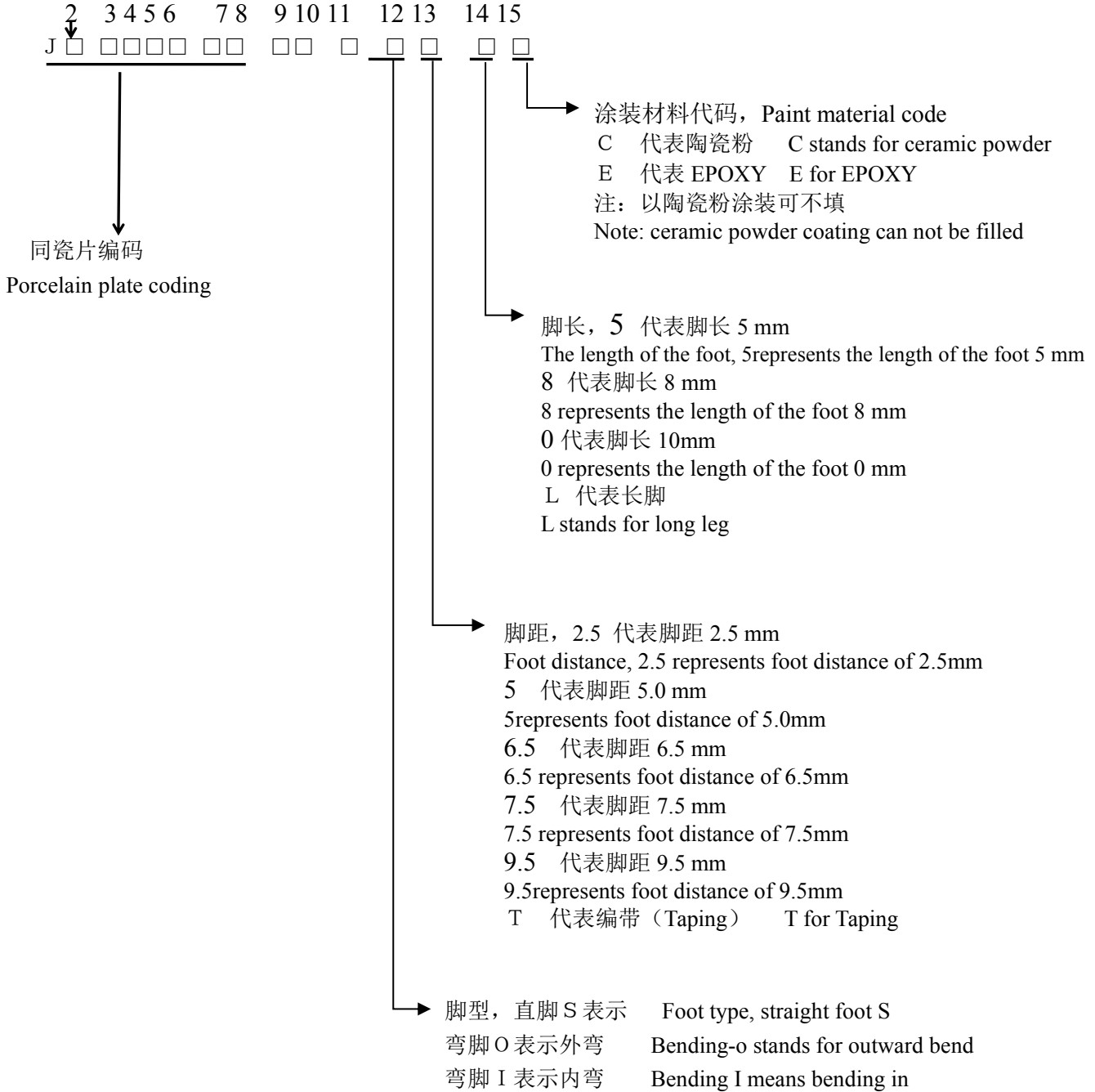

陶瓷瓷片 2-11 編碼規定如下:

The coding of ceramic tiles 2-11 is specified as follows

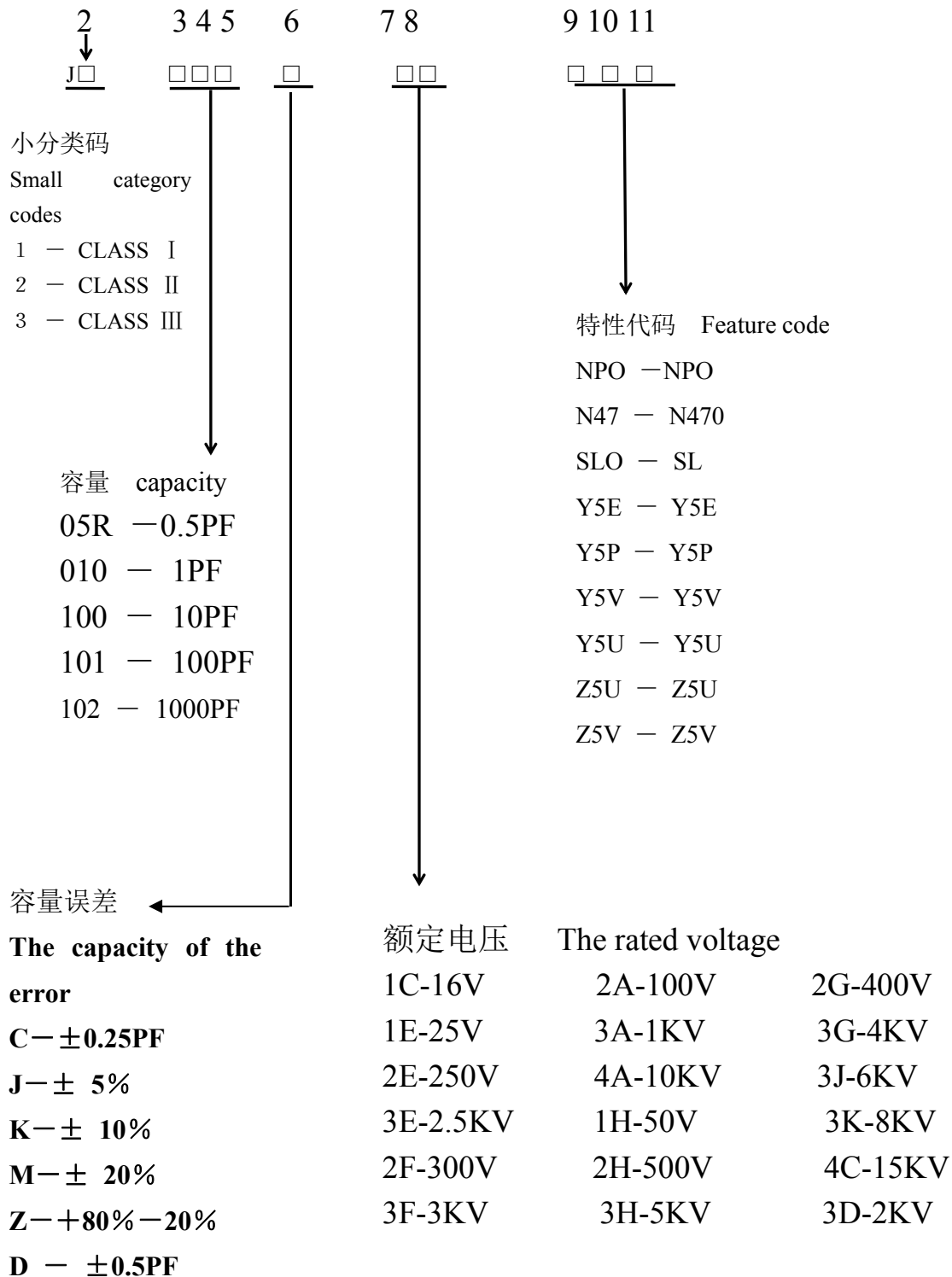

Porcelain capacitor shape specification:

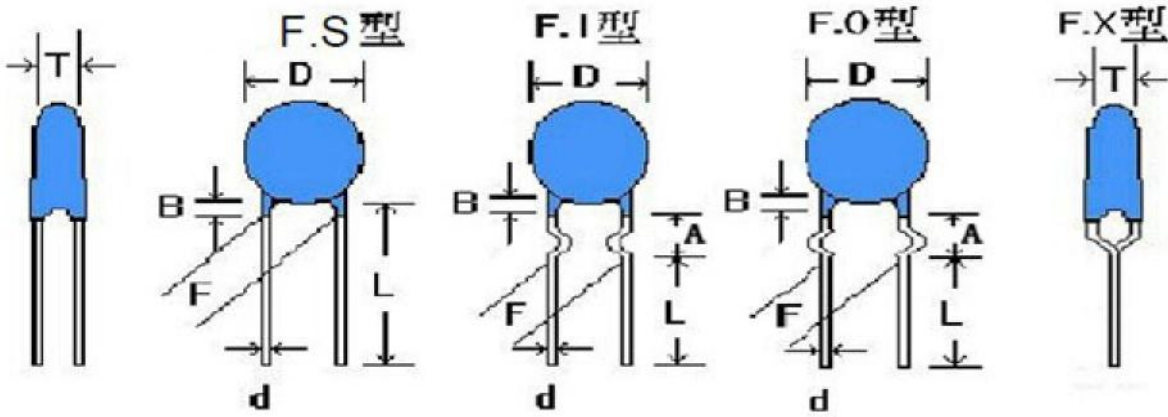

MODE	W.V	T m/m	d m/m	L m/m	F m/m	B m/m
F.S	12V - 100V	3 m/m	0.45 ± 0.05m/m	3 - 25m/m	2.50 m/m ± 0.8	2m/m
	500V - 1KV	3 m/m	0.48 ± 0.05m/m	3 - 25m/m	5.0 m/m ± 0.8	
	2KV - 3KV	4 m/m	0.55 ± 0.06m/m	3 - 25m/m	6.35 m/m ± 0.8	
	4KV - 8KV	6 m/m	0.55 ± 0.07m/m	3 - 25m/m	7.50 m/m ± 0.8	
	10KV - 15KV	8-10 m/m	0.55-0.80 ± 0.08m/m	3 - 25m/m	9.52-12.0m/m ± 0.8	
F.I	12V - 100V	3 m/m	0.48 ± 0.07m/m	3 - 25m/m	5.00 m/m ± 0.8	4m/m
	500V - 10KV	8 m/m	0.55 ± 0.08m/m	3 - 25m/m	9.50m/m ± 0.8	

- CLASS 1 TEMPERATURE COMPENSATING CAPACITOR
- CLASS 2 HIGH DIELECTRIC CONSTANT CAPACITOR
- CLASS 3 SEMICONDUCTIVE CAPACITOR
- CLASS 1.2. HIGH VOLTAGE CERAMIC CAPACITOR
- CLASS 1.2.3. APING SPECIFICATIONS

Packing Quantity

Pack	Safety Y1	Safety Y2	High Voltage	Ceramic DC
10 -332PF	1000PCS	1000pcs	1000pcs	1000PCS
472-103pF	500PCS	1000PCS	1000PCS	1000PCS
223-104pF	/	/	500PCS	1000PCS



TAPING SPECIFICATIONS

Taping (Radial)

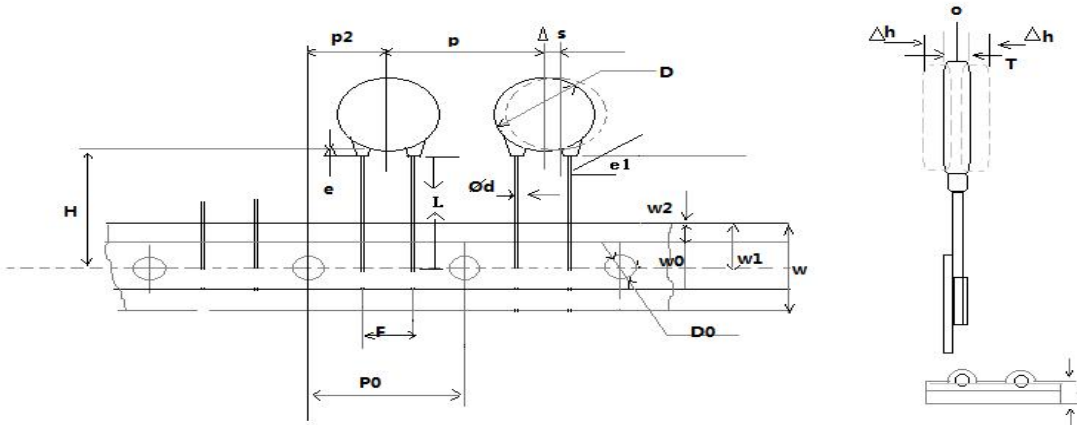

图片中没有注明 P0 数据的都是孔距 12.7mm

Item	Code	Dimensions (mm)	Item	Code	Dimensions (mm)
Taping Pitch	P	12.7±1.0	Lead Protrusion	l	+0.5~1.0
Guide Pitch	Po	12.7±1.0	Diameter of Feed Hole	Do	4.0±0.3
Lead Spacing	F	5.0±0.8 7.5±0.8	Diameter of Lead	d	0.55±0.06 -0.05
Feed Hole Position Capacitor Body	P2	6.35	Total Thickness of Tape	t	0.7±0.2
Feed Hole Position Capacitor Lead			Thickness of Capacitor Body	T	Differ in each product
Diameter Of ISO	D	See table of each series	Alignment to FR. Direction	Δ h	0±2.0
			Length of snapped Lead	L	17.0 +2.0 -1.0
Width Of Base Tape	W	18.0±0.5	Width of Hold-down Tape	Wo	12.5
Feed Hole Vertical Position	W1	9.0 +0.75 -0.05	Hold-down Tape Position	W2	1.5±1.5
Taping Height	For Straight	Ho	Coating Extention	e	3.0 以下
	For Crimp	H		e1	up to center of crimp

AMMO PACK

REEL

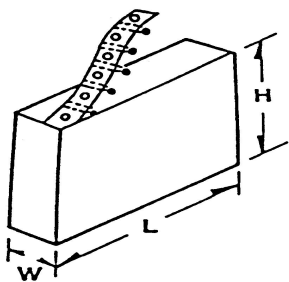

H = 234 ± 5 mm
L = 345 ± 5 mm
W = 50 ± 3 mm

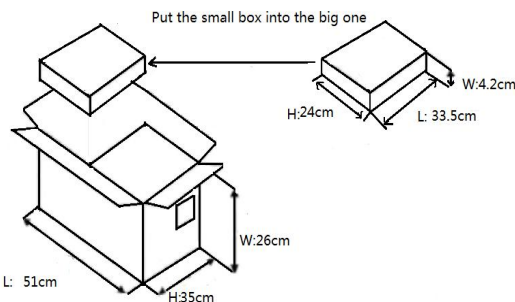

1. Tape box:

Part \ F	50V-2KV	3KV-6KV	6KV-
10-222PF	2000pcs	1500pcs	1200PCS
332-472PF	2000PCS	1500PCS	1500PCS
103PF	2000PCS	1000PCS	1000pcs

2. each large box can hold ten small boxes.

Acceptable to standard radial type cartridge.

■ **HIGH VOLTAGE** TEMPERATURE COMPENSATING CAPACITOR

Applications:

- Resonant circuit.
- High Q requirement.
- High stability Cap. Char.

Specifications:

Capacitance C	Range	1 PF ~ 680PF					measured at 1MHz±10%, 1.0 – 5.0 Vrms, 25°C	
	Tolerance	Code	C	D	J	K		
			±0.25 PF	±0.5 PF	± 5 %	± 10 %		
Quality Factor(Q)	C ≥ 30 PF	Q ≥ 1000						
	C < 30 PF	Q ≥ 400 + 20 × C						
Insulation Resistance (I R)		10000 MΩ min, measured at W.V.D.C, but not exceeding 500 VDC.						
Voltage	Working voltage (W.V.)		500V ~ 10KV DC					
	Test Condition		Test Voltage	Time	Current			
		W.V. = 500V	3.0 × W.V.	1 ~ 5 sec.	< 50 mA			
		W.V.= 1KV/2KV	2.0 × W.V.	1 ~ 5 sec.	< 50 mA			
		W.V.= 3KV/5KV	1.5 × W.V.	1 ~ 5 sec.	< 50 mA			
	W.V. ≥ 6KV	1.2 × W.V.	1 ~ 5 sec.	< 50 mA				
Operating Temp. Range	Type Code	Temperature Coefficient (PPM/ °C)		Temp. Range				
	NPO	± 0		- 2 5 °C t o + 8 5 °C				
	SL	+350 ~ -1000						
	The reference temperature: 25 °C							

T. C.CHART

■ **HIGH VOLTAGE** HIGH DIELECTRIC CONSTANT CAPACITOR

Applications:

- By-pass and coupling.
- Frequency discriminating circuits where Q and stability of Cap. Char. are not major importance.

■ **HIGH VOLTAGE** HIGH DIELECTRIC CONSTANT CAPACITOR

Applications:

- By-pass and coupling.
- Frequency discriminating circuits where Q and stability of Cap. Char. are not major importance.

Specifications:

Capacitance (C)	Range	100 PF ~ 47000PF measured at 1KHz ± 10%, 1.0 — 5.0 Vrms, 25°C				
	Tolerance	Code	K	M	Z	P
			± 10%	± 20%	+ 80%, - 20%	+ 100%, - 0%
Dissipation Factor (D.F)	2.5% Max.	at 1KHz, 1.0 Vrms, 25°C for Y5E , Y5P,Z5U				
	5.0% Max.	at 1KHz, 1.0 Vrms, 25°C for Z5V				
Insulation Resistance (I R)	10000 MΩ min, measured at W.V.D.C, but not exceeding 500 VDC.					
Voltage	Working voltage (W.V.)	500V ~ 10KV DC				
	Test Condition			Test Voltage	Time	Current
		W.V. = 500V		3.0 × W.V.	1 ~ 5 sec.	< 50 mA
		W.V.= 1KV/2KV		2.0 × W.V.	1 ~ 5 sec.	< 50 mA
		W.V.= 3KV/5KV		1.5 × W.V.	1 ~ 5 sec.	< 50 mA
W.V. ≥ 6KV		1.2 × W.V.	1 ~ 5 sec.	< 50 mA		
Operating Temp. Range	Type Code	Max. Change in Cap.			Temp. Range	
	Y5E	± 4.7%				
	Y5P/X7R	± 10%			- 2 5 ° C t o + 8 5 ° C	
	Y5U	+ 22%, - 56%			- 2 5 ° C t o + 8 5 ° C	
	Y5V	+ 22%, - 82%			- 2 5 ° C t o + 8 5 ° C	
	The reference temperature: 25 ° C					